



ConveyingLine

smart solutions



METRO

Stand-alone material loaders

The METRO stand-alone loader range from Motan enables processors to automate a key area of the production process cost effectively, bringing significant benefits of improved efficiency and process management.

Plastic granulate is conveyed quickly and cleanly to the hopper of a processing machine, a drying bin or a day bin. Material is delivered exactly when needed keeping machines running and avoiding costly down time. Material wastage is eliminated and the workspace is kept clean and safe.

All METRO loaders are easy to install and simple to operate. They handle throughputs from 10 up to 1650lbs/h.





smart solutions, is an additional range of equipment for optimising and automating the production around plastics processing machines.

smart solutions: to increase productivity with the least capital expenditure.

All units can be combined or expanded in order to satisfy increasing and changing requirements. **smart solutions** help the plastics processor to equip their individual machines or production cells. In the case of injection moulding, extrusion or blow moulding machines, cost savings can be easily achieved with minimum outlay.

Individual applications and problems are rapidly solved and may be the first steps towards a later system solution. **smart solutions** correspond to Motan's high quality standard in spite of lower prices and are available through Motan's worldwide distribution and service network. All units may of course be integrated into system solutions.

- Material bins for clean and clearly arranged material storage
- Dryers for energy saving material drying to a defined residual moisture, or removing surface moisture and preheating of material
- Conveying equipment for automatic material transport and supply to the machine
- Dosing and mixing units for self colouring or addition of additives and regrind
- Mobile granulators for sprues and rejects as well as the introduction of regrind to the material flow
- Temperature control units to maintain the temperature for optimum conditioning of injection moulds

Examples for step-by-step automation of injection moulding machines.

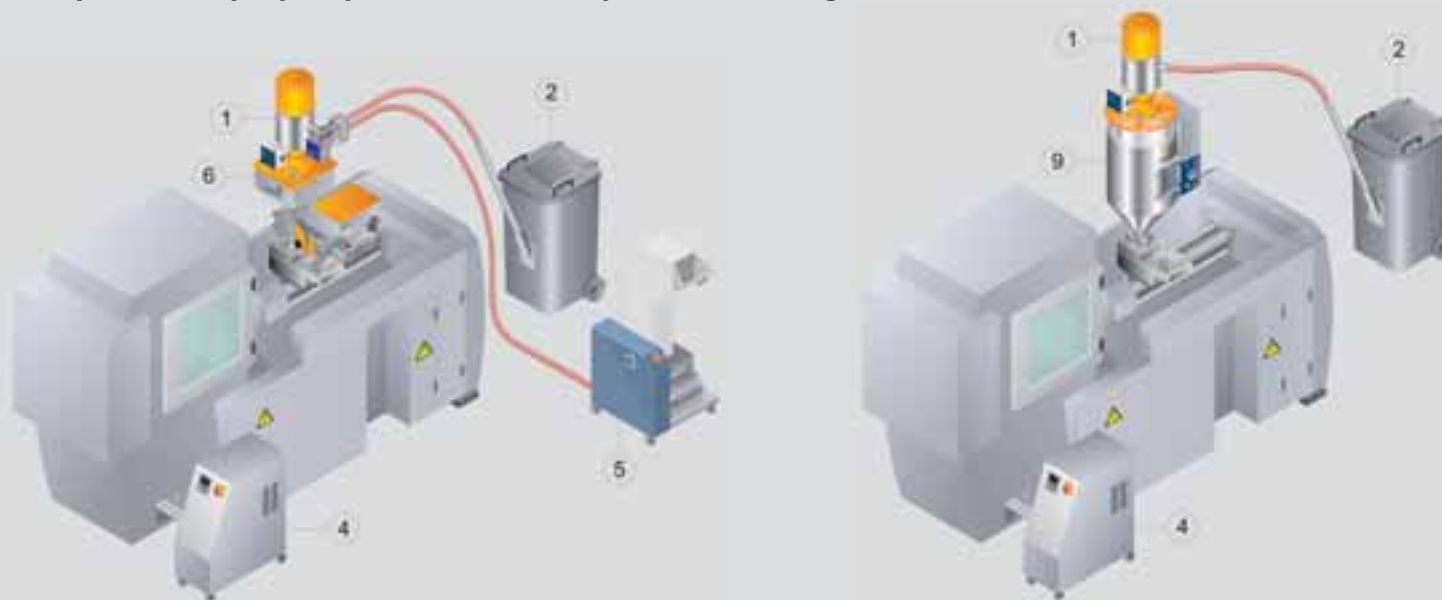

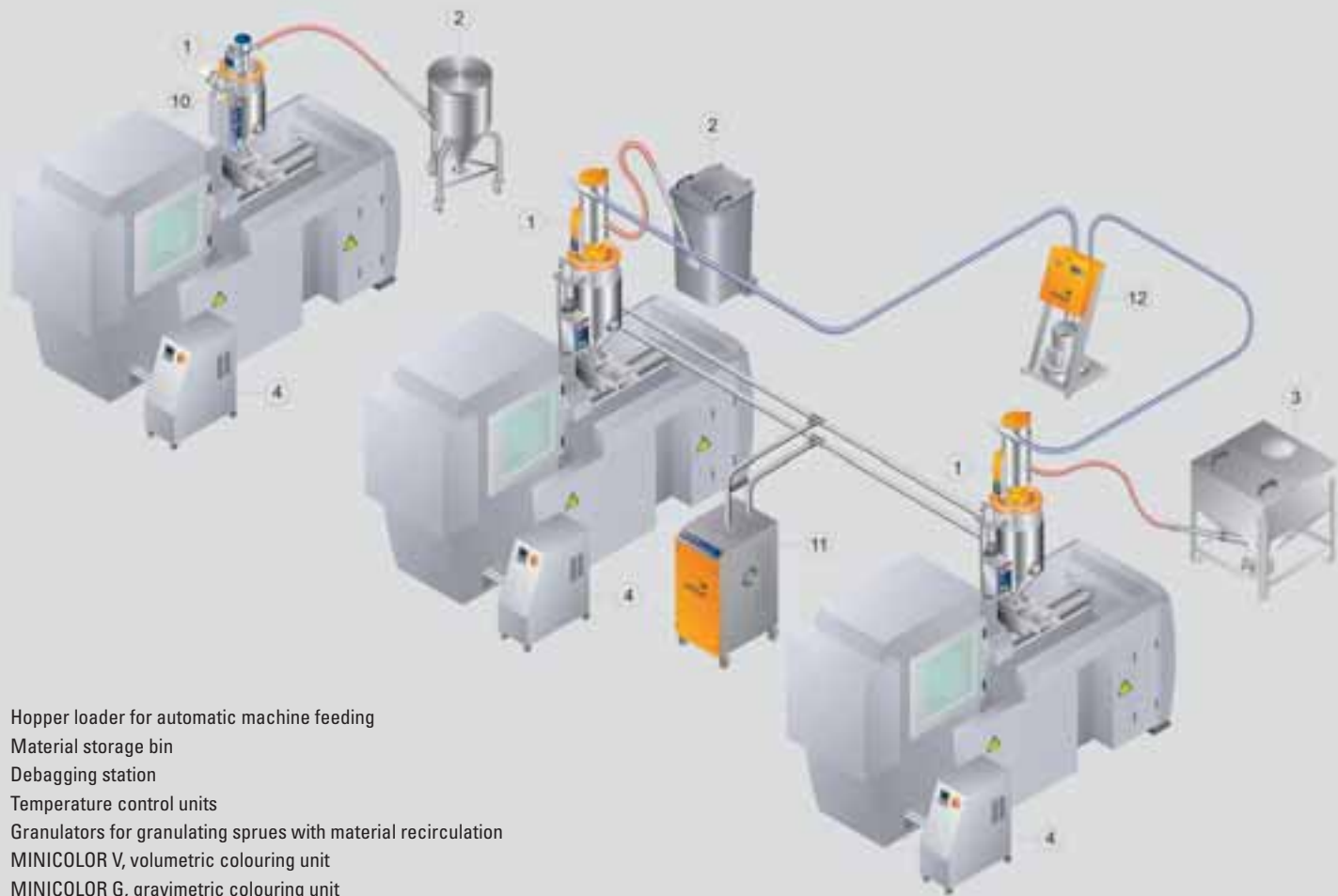

1. Hopper loader for automatic machine feeding
2. Material storage bin
3. Debagging station
4. Temperature control units
5. Granulators for granulating sprues with material recirculation
6. MINICOLOR V, volumetric colouring unit
7. MINICOLOR G, gravimetric colouring unit
8. GRAVICOLOR, dosing and mixing unit
9. LUXOR HD, hot air dryer
10. LUXOR CA, compressed air dryer
11. LUXOR, dry air dryer
12. Blower station
13. Central blower station with filter

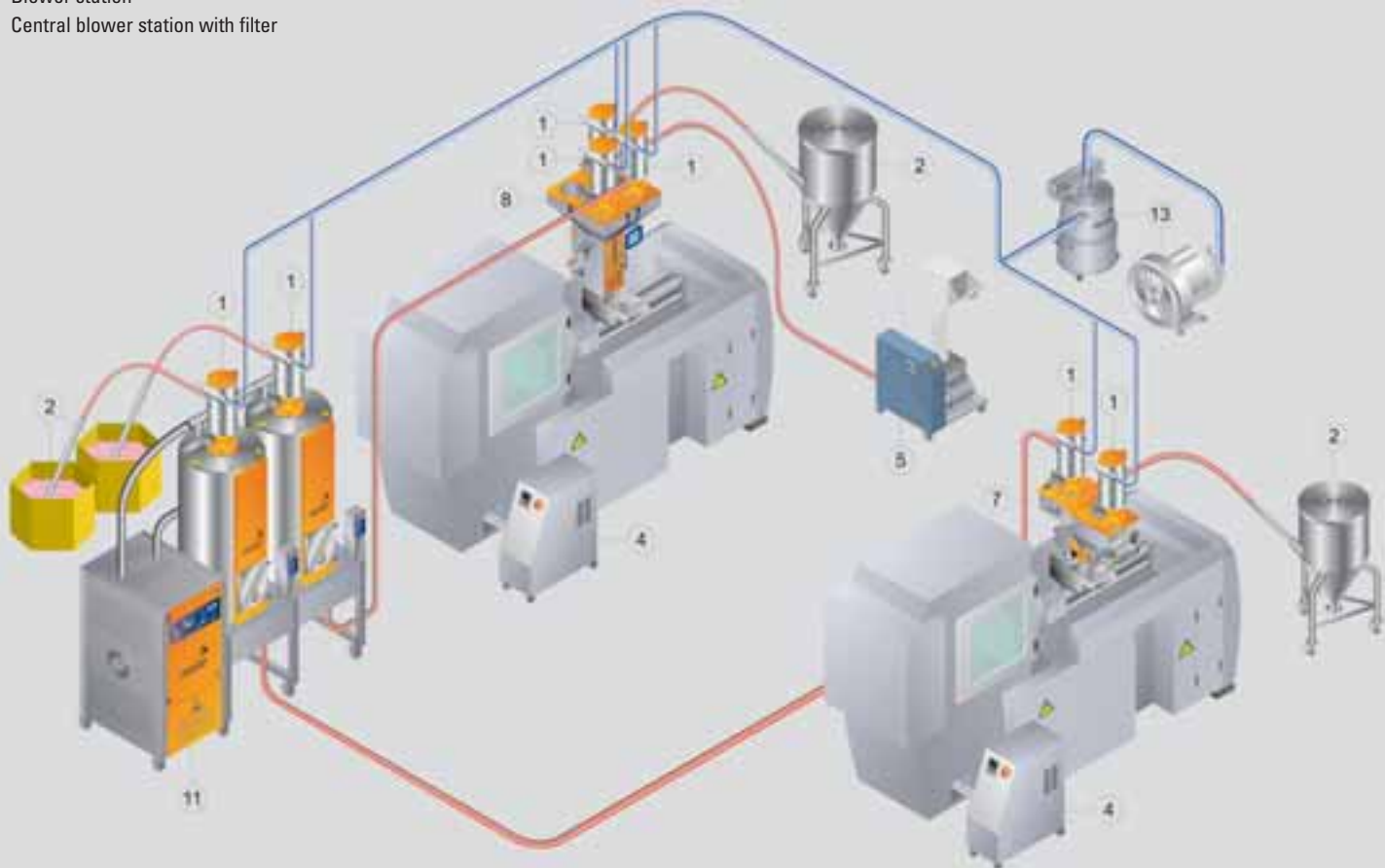



METRO VL



METRO MES 10



METRO HES 50



METRO HES 250



METRO HPS 06



METRO HBS 750/2



METROMIX

It is assumed that nowadays production downtimes due to empty machine hoppers do not occur. Hopper loaders automate the material feed to the machines. The cost advantage is obvious: clean production sites, no material loss due to spilled material, no risk of injury associated with manual filling of machine hoppers, better deployment of personnel and, in conjunction with material storage bins, no material mistakes. Finally, no production downtimes.

METRO VL

Venturi compressed air loader for small quantities.

METRO MES 10

Hopper loader with integrated vacuum motor, the most cost saving solution for a material throughput of up to 22lbs/h.

METRO HES 50

Hopper loader with vacuum motor, powerful and low noise for a material throughput of up to 110lbs/h.

METRO HES 250

Hopper loader with brushless vacuum motor, maintenance-free and powerful for a material throughput of up to 550lbs/h.

METRO HPS 06

Hopper loader to be used in small systems.

METRO HBS 750/2

Hopper loader with a three-phase blower for higher material throughputs.

METROMIX

Proportioning valve to add regrind may be supplied or retrofitted as necessary.



METRO VL

METRO VL

Venturi loader

The METRO VL loader is designed principally for manufacturers who produce small plastic parts and components.

This highly versatile compressed air loader can fulfil several different functions. It can be fitted directly to the throat of a small injection moulding machine to deliver up to 220lbs/h of virgin material. It can supply masterbatch feeders with masterbatch, a GRAVICOLOR blender with additives or a LUXOR CA compressed air dryer with virgin material.

Many features make the METRO VL very user friendly:

- It is light in weight
- Easy and quick to install
- Simple to operate and to clean
- Silent and wearfree operation
- Requires very little maintenance

The stainless steel construction ensures no contamination of material. An alarm indicates insufficient material.



LUXOR CA with METRO VL





METRO MES 10



METRO HES 10



METRO HES 50



METRO HES 50



METRO HES 250



METROMIX

METRO HES/MES

Single-phase loaders

These models are ready to use, self-contained, all purpose loaders designed for material throughputs from 22 to 550lbs/h.

They are fitted with an integrated vacuum motor, large filter and easy to operate controller. The conveying times are adjustable. An alarm indicates insufficient material.

The units can be mounted directly onto the throat of the processing machine (MES) or to a machine or material hopper (HES).

Noise insulation is fitted to the METRO HES/MES 50 and 250 making them quiet in operation.

The METRO HES/MES 250 models are equipped with reliable brushless motors and soft-start for wear-free operation.

All METRO HES/MES 50 and 250 models have a hinged lid for easy cleaning. METRO HES units are equipped with a large stainless steel discharge flap to ensure trouble-free operation. Filter cleaning after every conveying cycle by compressed air.

METROMIX

Proportioning valve

A stainless steel proportioning valve for mixing virgin and regrind material. The percentage and number of material charges per feed cycle can easily be adjusted. It can be retrofitted without difficulty. The METROMIX is easily cleaned via a large transparent access panel.





METRO HBS with blower



METRO HBS 250/2



METRO HBS

Three-phase loaders

The METRO HBS models offer a wide choice of loader-blower sets and are designed for higher throughputs, from 550 up to 1650lbs/h.

The units are supplied with a separate three-phase floor standing blower station which is low noise and maintenance free. The control panel is located at a convenient height, eliminating the need to climb onto the processing machine. An alarm indicates insufficient material.

Highly efficient automatic implosive filter cleaning is standard on all METRO HBS loaders.

METRO HBS units are also available with two material inlets. A separate mixing valve is not needed, as the METRO HBS loader has an integral proportioning function for virgin and regrind material. The ratio between the materials is precisely adjustable, so that the loader delivers a completely homogeneous mixture.

Up to two loaders plus a blower station can be controlled through a single control panel. In effect, processors can set up a small conveying system, with METRO HBS loaders serving either two machines or one machine and a drying bin.





METRO HPS 06



METRO MPG 1.5



GRAVInet



GRAVInet

METRO HPS/HPG

Loaders for small systems

Modularity

- The Motan METRO range with 0.5 to 30 lbs/liters capacity.
- Modular design allows easy adaptation.
- Machine loaders replace the storage bins on the processing machines.
- The option of either a glass or steel hopper body is available for most loaders.

Implosion valve

All METRO HPS/HPG material loaders are fitted with a vacuum valve. The valve opens the vacuum line when material is being conveyed and closes with an airtight seal after the conveying phase. The reduced pressure in the loader then causes the implosion valve to open suddenly for a short time. The shock of this implosion cleans the material separation screen after each conveying cycle.

Convey control

GRAVInet is an automated control system for hopper loaders. The integrated convey control at the GRAVICOLOR blending units allows the control of up to seven hopper loaders.

Machine hopper

Hopper for mounting on the machine throat in stainless steel or glass.

Machine hopper	Gross filling quantity approx. (lbs/l)	Net filling quantity* approx. (lbs/l)	Hopper loader sizes (lbs/l)
2 litres, round, stainless steel	2.5	0.3	0.5/1.5/6/10
8 litres, round, glass	8	6	0.5/1.5/6/10
8 litres, round, stainless steel	8	6	0.5/1.5/6/10
10 litres, square	10.5	5	0.5/1.5/6/10
15 litres, square	15.5	10	0.5/1.5/6/10
15 litres, square	15.5	7	15/30
20 litres, round, glass	21.5	14	15/30
20 litres, round, stainless steel	21.5	14	15/30
30 litres, round, glass	28.5	21	15/30
30 litres, round, stainless steel	28.5	21	15/30
60 litres, square	64	48.5	15/30

* Filling quantity with hopper loader fitted.



Material bin, square



Material bin, round, stainless steel



Material bin, round, glass

Material bins

Profitability starts with a well thought-out material storage and the use of small and mobile storage bins.

Day bin, mobile

Connecting piece with locking cap for a suction probe of 1.5" - 2.36" diameter included.

For contamination free storage of granules and other operating supply items.

The day bins are made of plastic (HDPE). They are weather-proof and resistant against UV radiation.



Day bin, mobile



Material day bin, mobile

Volume (lbs/l)	120	240	360
B, in (mm)	10 (480)	23 (580)	24 (600)
L, in (mm)	22 (550)	29 (730)	34 (870)
H, in (mm)	57 (930)	43 (1075)	43 (1100)



Storage bin



Storage bin made of aluminium, 120/240/360 lbs/litres

Inlet for suction probe of 1.5" - 2.36" diameter included.

Compact design and mobile with three castors. Optional mounting of a suction box is possible.

Storage bin	120	240	360
Volume (lbs/l)			
Ø 1, in (mm)	24 (616)	24 (616)	32 (800)
Ø 2, in (mm)	2.6 (65)	2.6 (65)	2.6 (65)
Ø 3, in (mm)	4 (100)	4 (100)	4 (100)
H, in (mm)	36 (900)	45 (1150)	45 (1165)



Debagging container,
standard basic container 1



Debagging container made of aluminium, 400 lbs/litres

Bulk material container for storing plastics granulates.

Standard basic container 1

Hinged lid, grid insert, welded suction pipe at the side and hinged slide at the outlet included.

Standard basic container 2

Hinged lid, grid insert, screw socket for min. indicator, outlet flange for connection of a suction box or hinged slide included.

Optionally available for standard basic container 2: a suction box and the connection for a Motan loader.





METRO

METRO VL*

Loader type	METRO VL
Conveying capacity, lbs/h (kg/h)**	max. 66 (max. 100)
Mode of conveying	compressed air
Compressed air, oil and water free, psi (bar)	30 - 100 (2 - 7)
Air consumption, cfm (m³/h)	max. 45 (max. 78)
Power supply 1/N/PE (V/Hz)	115/60
Weight, lbs (kg)	4 (2)

METRO HES/MES*

Loader	METRO 10		METRO 50		METRO 250	
	HES	MES	HES	MES	HES	MES
Type						
Volume (lbs/l)	1		6		6	
Average conveying capacity, lbs/h (kg/h)**	22 (10)		110 (50)		550 (250)	
Blower capacity/connected load, W	700		1100		1100 brushless	
Filter cleaning	compressed air					
Compressed air, oil and water free, psi (bar)	73 - 102 (5 - 7)		73 - 102 (5 - 7)		73 - 102 (5 - 7)	
Power supply, 1/N/PE (V/Hz)	115/60		115/60		115/60	
Weight, lbs (kg)	13 (6)	12 (5.3)	25 (11.2)	23 (10.3)	26 (11.7)	24 (10.5)
Dimension						
H, in (mm)	18 (462)		23 (576)		24 (600)	
d1, in (mm)	6 (140)		8 (214)		8 (214)	
d2, in (mm)	8.5 (215)	4 (100)	8.5 (215)	6 (145)	8.5 (215)	6 (145)
METROMIX connection	-		yes		yes	

METRO HBS*

Loader type	METRO HBS 250	METRO HBS 350	METRO HBS 750
Volume (lbs/l)	6	6	15
Number of hopper loaders	1 or 2	1 or 2	1 or 2
Conveying capacity, lbs/h (kg/h)**	550 (250)	770 (350)	1650 (750)
Filter cleaning	implosion	implosion	implosion
Compressed air, oil and water free, psi (bar)	73 - 102 (5 - 7)		
Power supply, 3/PE (V/Hz)	480/60		
Number of material inlets***	1 or 2		
Weight, lbs (kg)	25 (11.5)	25 (11.5)	38 (17.2)
Dimensions			
H1, in (mm)	27 (695)	27 (695)	30 (760)
d1, in (mm)	8.5 (215)	8.5 (215)	12 (314)
d2, in (mm)	8.5 (215)	8.5 (215)	11 (280)
d3, in (mm)	1.5 (38)	1.5 (38)	2.36 (60)
d4, in (mm)	1.75 (45)	1.75 (45)	2.36 (60)
Blower station kW	0.9	1.3	2.2
Dimensions			
H2, in (mm)	36 (905)	36 (905)	36 (905)
B1, in (mm)	16 (410)	16 (410)	16 (410)
L1, in (mm)	16 (410)	16 (410)	18 (450)
d4, in (mm)	1.75 (45)	1.75 (45)	2.36 (60)

METRO HPS/HPG

Loader type	0.5	1.5	6	10	15	30
Volume (lbs/l)	0.5	1.5	6	10	15	30
Weight, lbs (kg)	9.9 (4.5)	11.0 (5)	21.6 (9.8)	23.2 (10.5)	34.8 (15.8)	36.8 (16.7)
Dimensions						
H, in (mm)	12.17 (309)	15.83 (402)	23.03 (585)	25.55 (649)	27.68 (703)	31.61 (803)
d1, in (mm)	5.31 (135)	5.31 (135)	8.46 (215)	8.46 (215)	12.40 (315)	12.40 (315)
d2, in (mm)	1.5/1.75 (38/45)	1.5/1.75 (38/45)	1.5/1.75/2.36 (38/45/60)	1.5/1.75/2.36 (38/45/60)	1.75/2.36 (45/60)	1.75/2.36 (45/60)
d3, in (mm)	1.75 (45)	1.75 (45)	1.75 (45)	1.75 (45)	2.36 (60)	2.36 (60)

METROMIX* (option for METRO HES 50 and HES 250)

Connecting dimension, in (mm)	1.5 (38)
Mixing ratio (virgin : regrind)	90:10 up to 10:90
Compressed air, oil and water free, psi (bar)	73 - 102 (5 - 7)
Connected load, W	8.5
Power supply, 1/N/PE (V/Hz)	115/60
Weight incl. control, lbs (kg)	7 (3.3)

* The following items are included with delivery: 10ft (3m) material hose and a stainless steel suction pipe. In addition, METRO HBS hopper loaders are delivered with 16ft (5m) vacuum hose.

** The conveying capacity refers to a conveying distance of 16ft (5m) at a height of 10ft. The information refers to materials with a bulk density of 40lbs/cu ft (0,6kg/dm³).

*** When connecting two hopper loaders, a maximum of one hopper loader can be equipped with two material inlets.

Subject to technical changes.



METRO VL

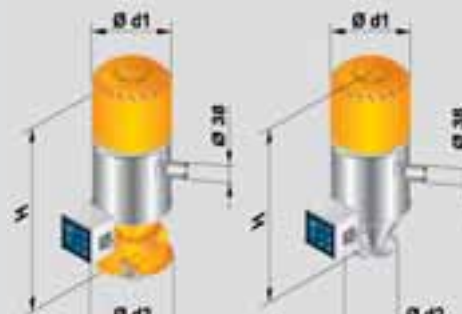

METRO HES

METRO MES

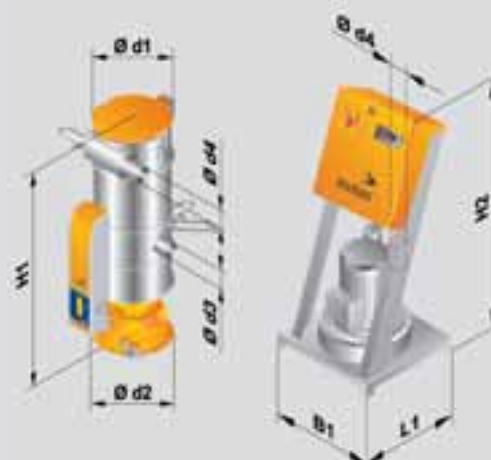

METRO HBS

Blower station

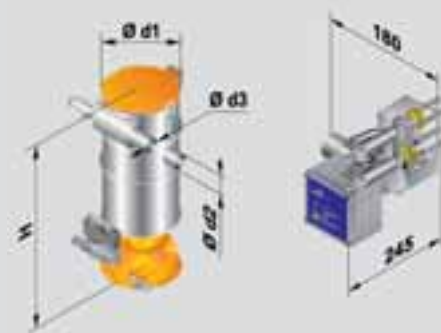

METRO HPS

METROMIX



Your benefits

Improved production efficiency through

- proven Motan quality for trouble free, reliable operation
- a first step to efficient, automated production
- processing machine which does not run empty – automatic alarm prompts for material supply
- avoiding health and safety risks – no material spillage, resulting in clean, safe floors and workspace
- possibility of proportioning of regrind
- easy access for cleaning
- automatic filter cleaning

Cost savings through

- material savings at least 1 to 2% – no spillage
- manpower savings through automated material conveying – no manual delivery and loading
- stainless steel construction – long service life
- low maintenance

Motan Pte. Ltd.
China/Beijing
Tel +86 10 6525-8815/16/17
Fax +86 10 6522-2522
motanbj@motan.com.cn

Motan Pte. Ltd.
China/Shanghai
Tel +86 21 6351-2999
Fax +86 21 6351-3555
motansh@motan.com.cn

Motan SAS
France
Tel +33 1 608690-18
Fax +33 1 608690-29
info@motan.fr

Motan GmbH/North
Germany
Tel +49 5223 68544-0
Fax +49 5223 68544-11
motan.ger.n@motan.de

Over 90 agencies world-wide * Partners

Motan GmbH/South
Germany
Tel +49 7562 76-0
Fax +49 7562 76-111
motan.ger.s@motan.de

Motan Ltd.
Great Britain
Tel +44 1235 5500-11
Fax +44 1235 5500-33
sales@motan.co.uk

Motan India Liaison Office
India
Tel +91 44 2445-3779
Fax +91 44 2440-4196
motan.india@motan.com

Motan S.r.l.
Italy
Tel +39 02 9272121
Fax +39 02 92148392
motan.it@motan.com

Motan Pte. Ltd.
Singapore
Tel +65 6873-7666
Fax +65 6873-7555
motansin@motan.com.sg

Motan AG
Switzerland
Tel +41 41 74861-11
Fax +41 41 74861-10
info@motan.ch

Motan Pte. Ltd.
Thailand
Tel +66 2 717-1088
Fax +66 2 717-1080
motanth@motan.co.th

Motan Inc.
USA/Plainwell
Tel +1 269 685-1050
Fax +1 269 685-1059
motanusa@motan-inc.com

Semmil*
Brazil
Tel +55 11 5522-2200
Fax +55 11 5687-5012
vendas@semmil.com.br

Sangyokiden Co. Ltd.*
Japan
Tel +81 82 928-6150
Fax +81 82 928-9954
info@sangyokiden.co.jp



03_08_1.5

power to change

www.motan.com